

DOOR LOOP SDM 40

Door loop type SDM 40 - is a wire conduit to protect exposed wires in order not to be damaged.

PROPERTIES

- : Door loops are **protective means for guiding wires from the frame to doors with installed electrical devices** such as electric locks.
- : **Can be attached to a tapered panel with a width of 25 mm.**
- : It needs a **minimum of space**. It is suitable for narrow door spaces due to its small design.
- : **Easy to maintain.**



DIMENSIONS



TECHNICAL SPECIFICATIONS

Model:	SDM 40
Connector material:	Embedded box and connector: Iron
Conduit material:	Spring steel
Inner diameter of the conduit:	10,4 mm
Outside diameter of the conduit:	13,8 mm
Length of the conduit:	416
Total length:	490 mm
Weight:	448 g

STRUCTURE DIAGRAM

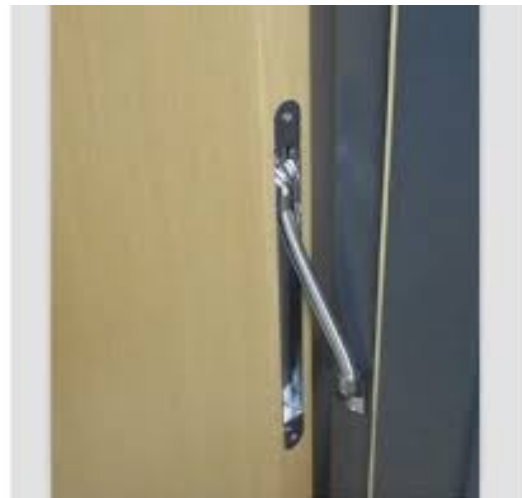
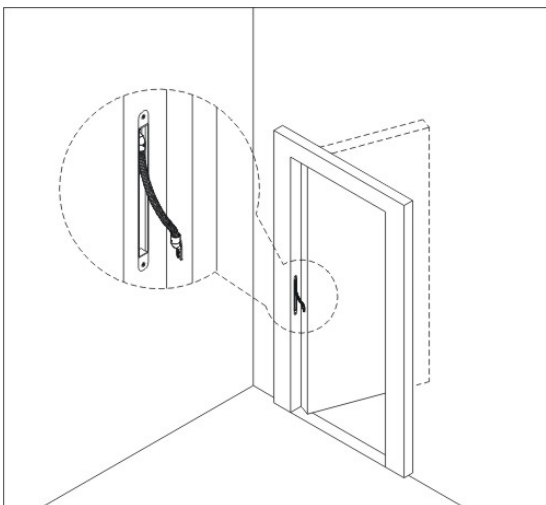

The leader in door opening solution
www.zadlabacipruchocky.cz
www.acssolution.cz

Updated: 9/2022 | ACS Solution s.r.o. Specifications are subject to change without prior notice. Note: The colors of the images in this brochure may differ from the actual colors.